

# **PRO Series**



INNOVATION IN CONTAINER INSPECTION



# TapTone PRO Series

---

## Inspection Flexibility to Meet the Changing Demands of Today's Production Lines

Managing the dynamic landscape of today's production facilities can be challenging. Product changeovers and new product introductions often require plant managers to adapt existing equipment with little time and limited budget. The TapTone PRO Series was developed to address this need in the market and gives facilities the ability to move, change, and add inspection capabilities as required. The sensors are all designed to suspend over the customer's existing conveyor. Multiple sensors can be added to a single user interface offering a cost effective inspection solution at a single point or multiple points on the production line. The PRO Series User Interface can display up to 4 sensor outputs simultaneously allowing for at-a-glance monitoring of multiple inspections. In addition, plant controls allow plant level monitoring from a remote location via an ethernet connection.

### Sensors for Leak Inspection

- Acoustic
- Proximity
- Dual Sensor Compression
- Force Stainless

### Sensors for Vision Inspection

- TotalVu
- SelectVu

### Sensors for Fill Level

- Fill\_xr
- TotalVu
- SelectVu

### Rejectors

- Segment8
- TapTone HighSpeed
- TapTone Case

*Discover the power and flexibility of the new PRO Series line of sensors from Teledyne TapTone.*

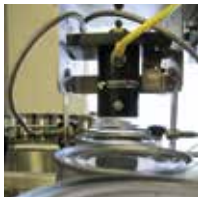

### SINGLE LINE OPERATION

The TapTone PRO Series system gives users the greatest flexibility for product changeover and sensor expansion. All PRO Series sensors are designed for plug and play performance with the PRO Series user interface. Design the line you need today with the confidence that you can expand capabilities later to adapt to changing requirements.

Fill\_xr

Proximity

Ram Rejector

Reject table

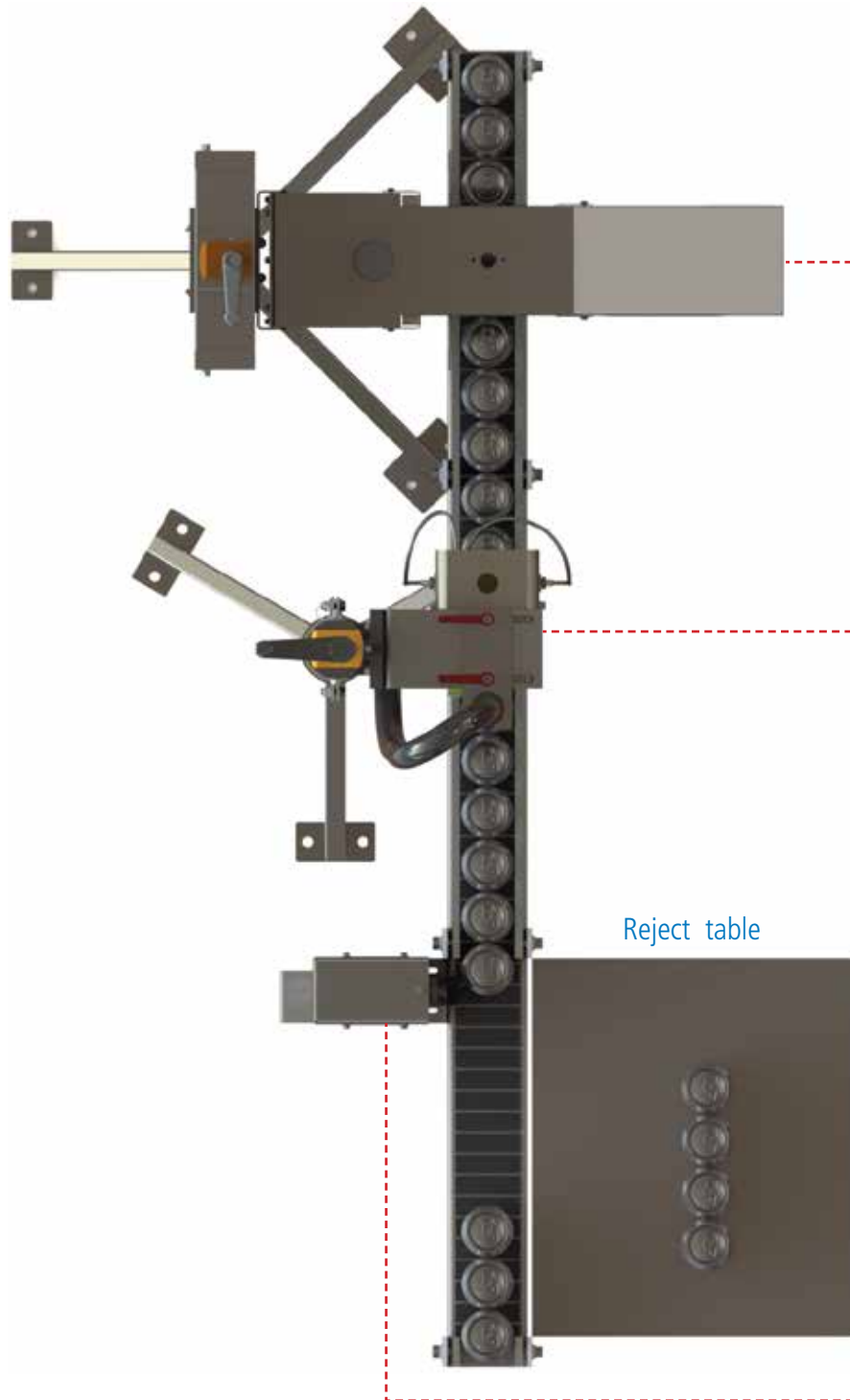

### MULTI-LINE OPERATION

Have an adjacent line that also requires inspection capabilities? Need to split a line to accommodate high volume production or create redundancy in the line? The PRO Series system was designed for this purpose. Two adjacent lines can run multiple sensors independent of one another but share a single user interface for control and monitoring. The PRO Series system gives the user maximum flexibility and efficiencies to handle the changing requirements of today's production lines.

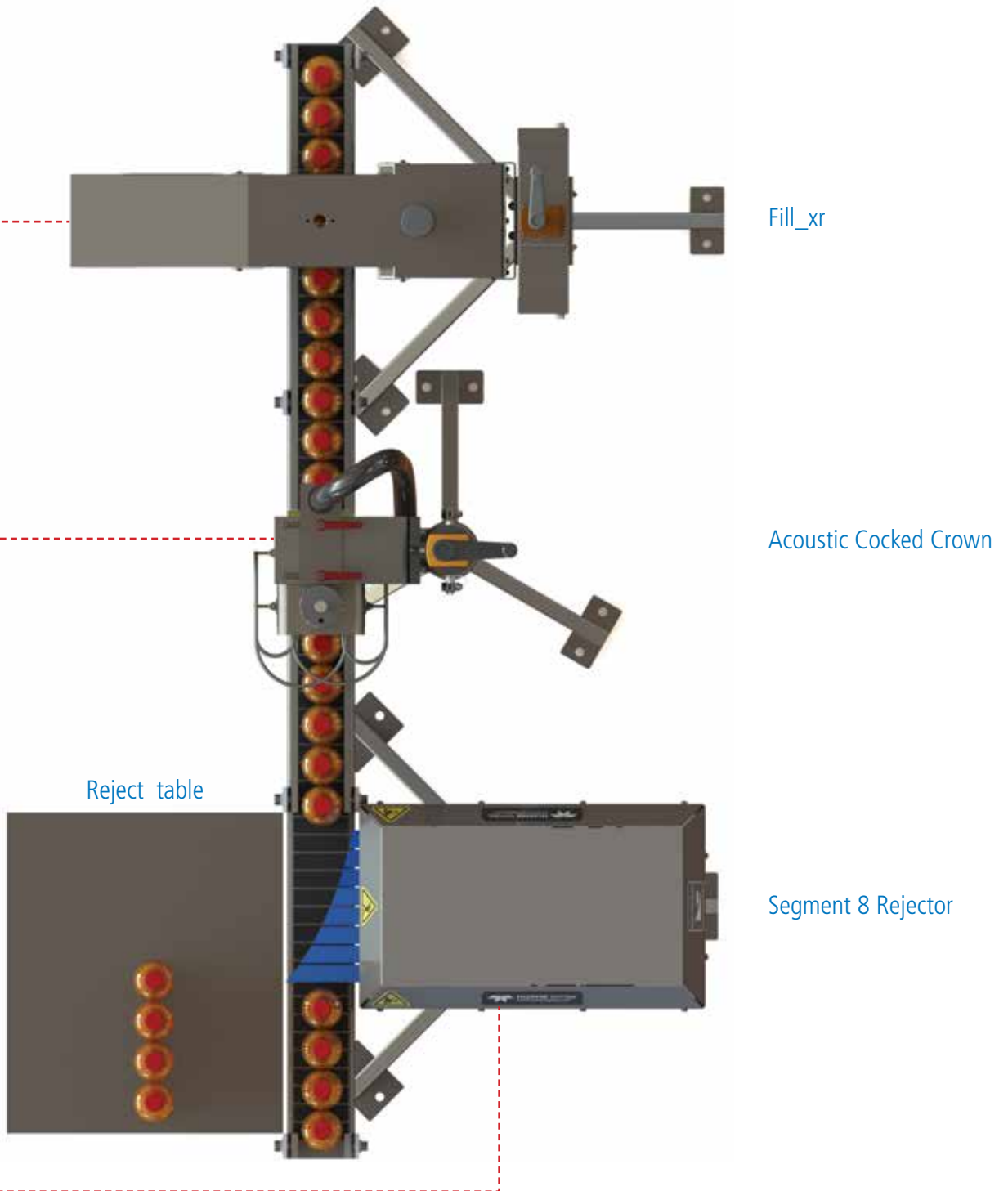

## Available PRO Series Sensors



### Dual Sensor Compression-DSC

The TapTone Dual Sensor Compression (DSC) Sensor is designed to inspect a wide variety of flexible containers for micro leaks. The design incorporates our patented dual sensor technology and high speed compression belts for improved accuracy and container handling. The system was designed for harsh environments. The sensor can be configured with low profile belts for handling small containers.



### TotalVu™

The TapTone TotalVu Vision Sensor is a non-contact visual package inspection sensor that can be configured with one to four "smart" cameras designed to capture multiple inspections in a single pass. Its multifunction design coupled with a small footprint and an attractive price point, gives customers several compelling advantages over larger and more expensive competitive units. The TotalVu system can operate as a stand-alone system or can be integrated with other TapTone inspection systems.



### Force Stainless-FS

The TapTone Force Stainless (FS) Sensor is designed to handle the higher pressure applications found with many aerosol containers and heavy duty aluminum can/bottle applications. The system inspects 100% of containers at production line speeds. The TapTone 4000-FS is manufactured with a stainless steel transport system for harsh environments. The reinforced side plates give extra rigidity for high pressure applications and allow for a stable reading with excellent resolution. The system can alternatively be fit with a mid-range or low range pressure sensor for applications that require all-stainless steel construction.



### SelectVu™

The TapTone SelectVu Vision Sensor is designed to perform visual inspection of containers using a single camera and lighting in a stainless steel enclosure. The sensor can be added to other TapTone inspections for leak and fill level or can be used as individual modules. Link up to four SelectVu sensors to a single user interface to create a modular and flexible vision inspection solution that can change to meet the demands of your production line. The sensor mounts on a remote variable height stand for easy adjustment and has minimal line space requirements.



### Acoustic

The TapTone Acoustic Sensor measures pressure or vacuum in containers with metal closures that do not have a measurable lid deflection. This sensor can be configured with an optional proximity sensor for cocked crown detection. Used primarily on metal crowns and ROPP metal closures.



### X-ray

The TapTone Fill\_xr sensor uses low energy X-ray technology to inspect steel, aluminum, plastic and glass containers for proper fill level. The system can be configured to detect underfilled and overfilled containers. The sensor mounts on a remote variable height stand and requires no modifications to the existing production conveyor.



### Proximity

The TapTone Proximity Sensor measures pressure or vacuum in containers with metal closures by measuring the lid deflection. Used primarily on cans and metal button up caps.





**Teledyne TapStone**

49 Edgerton Drive, North Falmouth, MA 02556

**Phone:** +1-508-563-1000 **Fax:** +1-508-564-9945

**E-mail:** [taptone@teledyne.com](mailto:taptone@teledyne.com)

**[www.taptone.com](http://www.taptone.com)**

10/2014. TAPSTONE is a registered trademark of Teledyne Instruments, Inc. Copyright 2014, TELEDYNE TAPSTONE.  
*Note: Features and specifications subject to change without notice.*

---

**Distributed by:**