

Yamato

Dataweigh™

SNACK VERSION

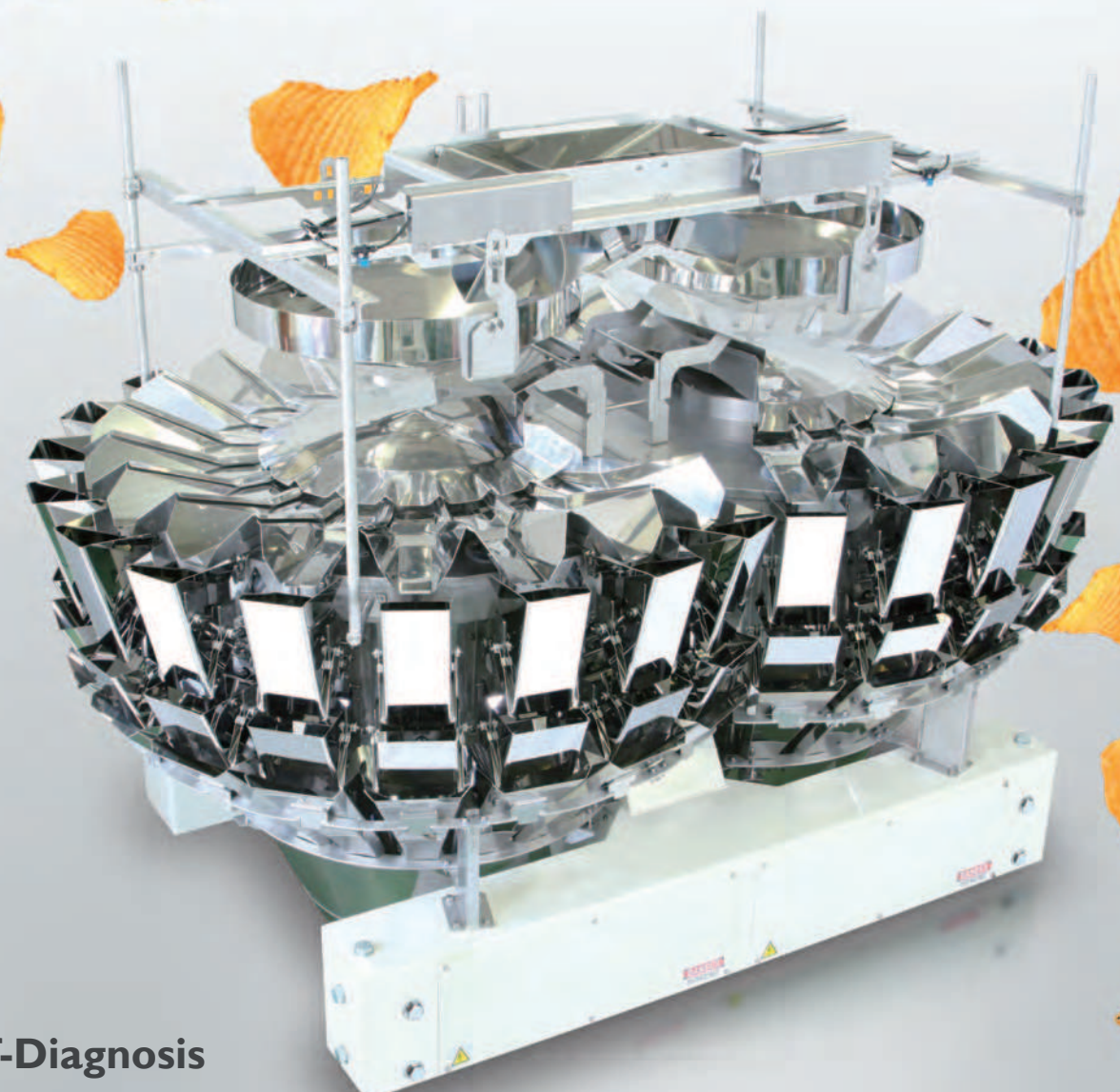

Self-Diagnosis
Self-Recovery
Optimum Control
Remote Maintenance

Dataweigh™ SNACK VERSION

The food industry has been driven by its own specific requirements for high speed weighing performance and as the fastest developing food sector, that demand is set to increase. In accelerating the drive for higher line speeds, Yamato has taken its extensive, well-proven multihead technology to provide tailored fast weighing system without compromising complete accuracy whilst ensuring long-term reliability and customer support.



E xcellent Hygiene

All operating systems, including the radial feeders are totally enclosed to provide superior hygiene. And, all product contact surfaces are removable without tools and feeder trays and buckets are fully interchangeable.

D rive System

Dataweigh™ uses accurate and repeatable stepper motors for bucket door actuation. Motor patterns are adjustable and programmable to ensure the highest speed and efficiency for a wide variety of products.

S pring-less Radius Corner Bucket

All bucket doors are driven by stepper motor without external springs. The stepper motor adjusts the action of the door quick or slow to meet the situation of the products character or the target weight. Since spring-free bucket reduces seasoning dust accumulation, it avoids the fault caused by dust penetration and clears the sanitary problem.

I ndividual Type Collating Chutes for ADW-A-0328SN

The Individual Type Collating Chutes are correctly set to aim the center point. The dumped products travel the same distance from any position of the bucket. The Individual Type Collating Chutes prevent the products from rotating on the chutes. The dumped products straightly slide down on the chutes surface in a moment.

B asic Features

- Reduces power consumption by up to 60 per cent
- Ensures a continuous and optimum product feeding
- Advanced maintenance concept to minimize downtime
- Features auto-tuning and automatic feeding control
- 10.4" color touch screen monitor for intelligent and user-friendly interface





ADW-A-0314S

The steep Collating Chute enables high-speed single discharge up to 140 weighs per minute. A proven and trusted design backed by a number of machines in the field.

ADW-A-0316MN

The stable discharge with 100 weighs for two single tubes. The dedicated Duck Mouth Collection Bucket works for optimum feeding into VFFS machines. The Diverter Infeed Funnel is incorporated as standard.

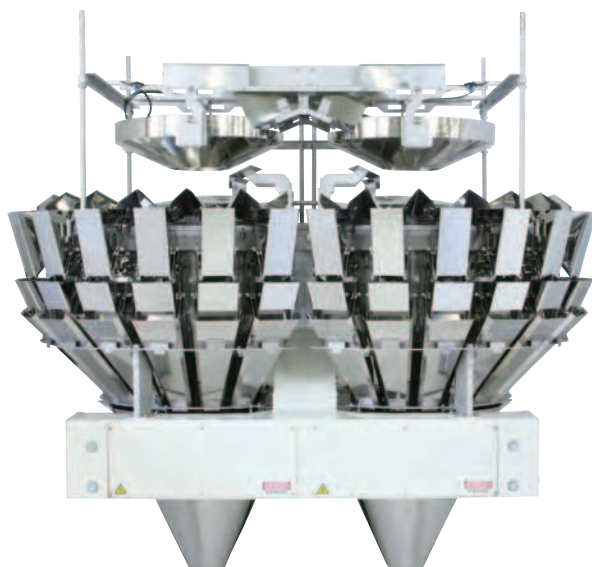

ADW-A-0328SN

Yamato presents a new solutions with the 28 head twin weigher which features new feeding control to increase accuracy and while reducing power consumption. Enhances productivity with two high-speed single tubes. The twin configurations of two high-speed VFFS machines for reduced footprint, enhanced performance and increased productivity per available floor space.



Dimensions

ADW-A-0314S

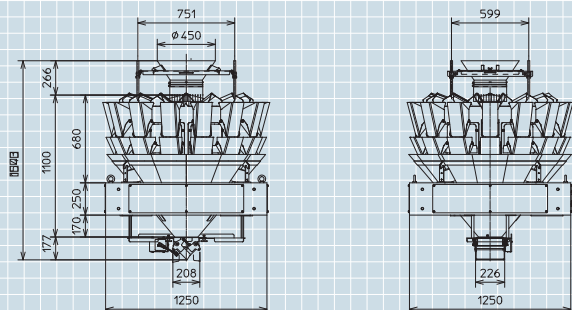

ADW-A-0316MN

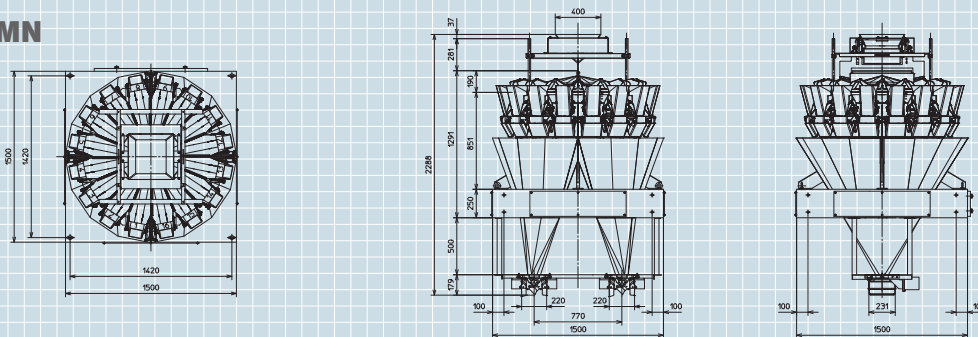

ADW-A-0328SN

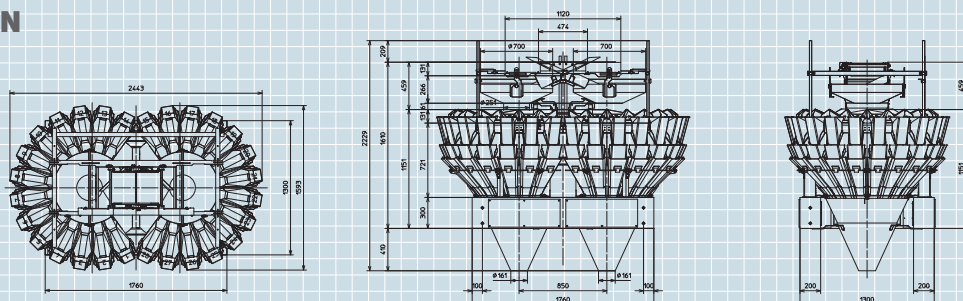

S Specifications

| Model | ADW-A-0314S | ADW-A-0316MN | ADW-A-0328SN |
|-------------------------|---------------------------------------|----------------------------|--------------|
| Number of Weigh Head | 14 | 16 (with memory bucket) | 28 |
| Max. Speed | 140 wpm | 2 x 100 wpm | 2 x 140 wpm |
| Max. Combination Volume | 3,000ml | | |
| Weighing Range | 4~500g (0.1g) | | |
| Max. Product's Length | 80mm | | |
| Number of Weigh Head | Stepper Motor Driven | | |
| Controller | RCU-920, 10.4inchi color touch screen | | |
| External Interface | USB, Ethernet, RS-232C | | |
| Operating temperature | -10°C~40°C | | |
| Humidity | 35~85%T (No condensation) | | |
| Net Weight | 350kg | 890kg | 1,240kg |

The machines are covered by a number of patent worldwide.
Above specifications and dimensions are subject to change without notice.



Easy Operation



Color Touch Screen Operator Interface

- 10.4 inch color touch screen
- User-friendly icons enables easy operation.
- Up to 300 pre-set programs can be memorized.
- 2 products mixing is available (ADW-A-0320S)

Self-diagnostics

All important system conditions, including voltages, input/output status, software versions, and analog/ digital converter can be monitored and diagnosed through- the color touch screen operator interface.

USB Memory port



- Data acquisition
- Program update

Network Remote Control and Data Acquisition

Network connection capabilities (optional)

- PC remote control by LAN
- Data acquisition via USB, Ethernet or RS232C
- Feed back control between checkweigher and multihead weigher

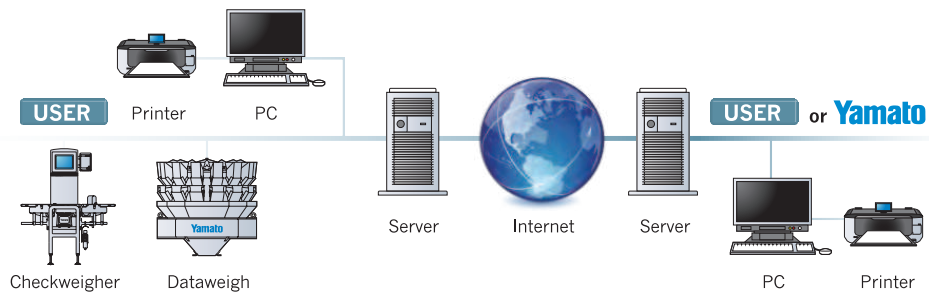

Production control function

Enter the number of packs you want for a certain recipe and once the production batch reach this number, the scale recipe can be automatically changed to the next one.

About Yamato & Dataweigh™

Yamato Scale Co., Ltd. was founded in 1920 and has always been a leading manufacturer in the world of weighing machinery. In 1979, the first Dataweigh ADW-110 was developed. Since then, we have introduced many groundbreaking technologies, creating today's high-speed and highly accurate multihead weigher 'Dataweigh Series', which is used throughout the world. Our headquarters are in Akashi, Japan, and we have regional offices in the U.S.A., Canada, Germany, Netherlands, U.K., France, Russia, China and India. We also have a joint-venture in Korea and cover more than 70 countries with our representatives. Our highly experienced sales and service network provides customers around the world with a high level of expertise and service.

■ On-site-service



Installation



Application



Training



Repairs



Maintenance



Helpdesk & hotline

■ In-house-service

Worldwide Sales & Service Network

Yamato is the only manufacturer of multihead weighers with wholly owned operations in America, Europe and Asia.

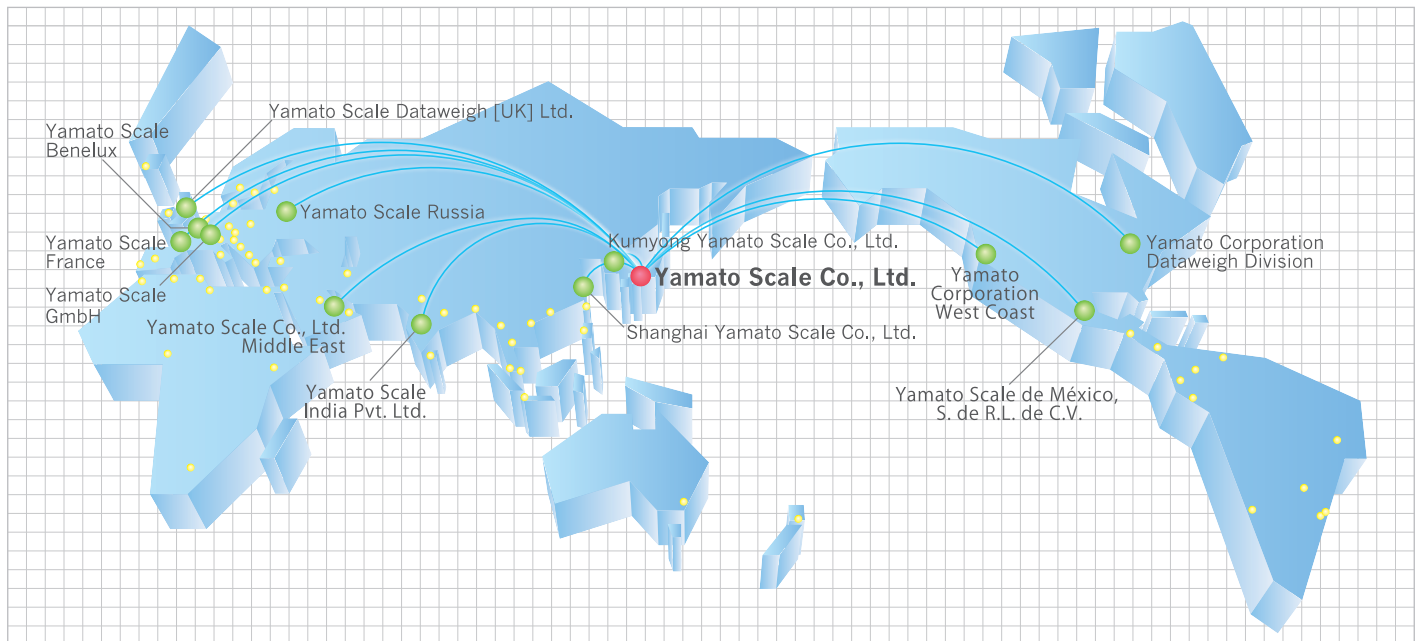

Spare Parts & Service

Yamato Spare Parts and Service are subject to the same high demands of quality as the machines themselves.



Speed, weight and volume listed are standard. Other ranges are also available when required, please contact Yamato. This machine is covered by number of patents worldwide. All illustrations and specifications are subject to change without notice.

YAMATO SCALE CO., LTD.

5-22 Saenba-cho, Akashi, Japan
673-8688
Telephone : +81(78)918-5566-5567-5568
Telefax : +81(78)918-5552
URL : <http://www.yamato-scale.co.jp/>

Yamato Scale GmbH

Hanns-Martin-Schleyer-Str. 13,
D-47877 Willich, Germany
Telephone : +49(0)2154 9159-0
Telefax : +49(0)2154 40626
URL : <http://www.yamatoscale.com/>
E-mail : sales@yamatoscale.com

LLC Yamato Scale

Lublinskaya str. 151,
109341 Moscow, Russia
Telephone : +7(495)620 4870
Telefax : +7(495)620 4877
URL : <http://www.yamatoscale.ru/>
E-mail : salesru@yamatoscale.com

Yamato Corporation Dataweigh Division

6306 W. Eastwood Court
Mequon, WI 53092 U.S.A.
Telephone : +1(262)236-0000
Telefax : +1(262)236-0036
URL : <http://yamatoamericas.com/>
E-mail : info@yamatoamericas.com

Yamato Scale France

3 Avenue du Canada, Bâtiment Gamma,
91940 LES ULIS, France
Telephone : +33(0)1 64 53 24 40
Telefax : +33(0)1 69 07 26 79
URL : <http://www.yamato.fr/>
E-mail : Vente@yamato.fr

Yamato Scale Benelux

Edisonstraat 4a, 5051 DS, Goirle,
The Netherlands
Telephone : +31(0)13 220 11 17
Telefax : +31(0)13 460 90 81
URL : <http://www.yamatoscale.nl/>
<http://www.yamatoscale.be/>
E-mail : ysb@yamatoscale.com

Yamato Scale de México, S. de R.L. de C.V.

Av. Dr. Gustavo Baz 191, Bodega F
Col. El Mirador, CP. 54080, Tlalnepanitla
de Baz, Estado de México, México
Telephone : +52(55)2628-6140
URL : <http://yamatoamericas.com/>

Yamato Scale Dataweigh [UK] Ltd.

3 Maple Park, Lowfields Avenue, Leeds,
LS12 6HH, England
Telephone : +44(0)113 322 1546
Telefax : +44(0)113 350 2020
URL : <http://www.yamatoscale.co.uk/>
E-mail : sales@yamatoscale.co.uk

Shanghai Yamato Scale Co., Ltd.

368, Qingda Road, Heqing Industrial Field, Pudong,
Shanghai, ZIP code 201201, China
Telephone : +86(21)58973377
Telefax : +86(21)58973737
URL : <http://www.yamatosh.com>

Yamato Corporation-West Coast

Suite 1205 22600F Lambert Street
Lake Forest, CA 92630
Telephone : +1(949)238-4500
URL : <http://www.YamatoAmericas.com>

Yamato Scale India Pvt. Ltd.

B-104, Okhla Industrial Area, Phase-I,
New Delhi 110020, India
Telephone : +91(11)4607 2882
Telefax : +91(11)4607 2881

Yamato Scale Co., Ltd. Middle East (Branch)

Dubai Airport Freezone
LIU-A07, P.O Box : 371911
Telephone : +971(0)42952730
Telefax : +971(0)42952729
E-mail : yamato@yme-01.ae