



**Thermo Scientific VersaWeigh**  
General purpose checkweigher

- Broad range of applications
- High accuracy and stability
- Very easy to use and maintain

## **versatile checkweighers**

for a wide range of package sizes,  
weights and speeds

The Thermo Scientific VersaWeigh checkweighers provide high accuracy and rates to improve your efficiency and profitability. Ease of use reduces training costs and modular design minimized downtime.

# Thermo Scientific VersaWeigh Checkweigher

Specifications by Model	10-015	Pharma <sup>†</sup>	20-015/030	30-015/030/060	40-30-060-100	Box 25 <sup>‡</sup>
VersaWeigh Model	10-015	Pharma <sup>†</sup>	20-015/030	30-015/030/060	40-30-060-100	35/45-120/250 <sup>††</sup>
Weigh Range	1.5 kg	1.2 kg	1.5/3.0 kg	1.5/3.0/6.0 kg	3.0/6.0/10.0 kg	12/24 kg
Belt Width (BW)	100 mm	80-140 mm	200 mm	300 mm	400 mm	350-450 mm
Infeed Length (IL)	350, 500 mm	350-500 mm	250-1000 mm	350-1000 mm	500-1000 mm	600-800 mm <sup>†</sup>
Combo Infeed Length (CL)	600-700, 800 mm	Consult factory	600-1000 mm	600-1000 mm	700-1000 mm	Consult factory
Weigh Table Length (WL)	200, 250 mm	200-250 mm	250-500 mm	350-600 mm	500-800 mm	600-800 mm
Outfeed Length (OL)	350, 500 mm	350-500 mm	250-1000 mm	350-1000 mm	500-1000 mm	600-800 mm <sup>†</sup>
Roller Diameter	16 mm	16 mm	24 mm/27 mm	34 mm	34 mm	49 mm
Tubing Diameter	50 mm	50 mm	50 mm	75 mm	75 mm	64 mm
Motor Type	100 W	100 W	200 W	400 W	400 W	400 W

## Specifications Common to All Models

Material	Integrated, stainless-steel conveyors and frame; Optional stainless-steel, free-standing infeed/outfeed; Pulleys: aluminum
Interface Languages	Multi-language interface standard
Data Communication Options	USB; serial; parallel; FTP Ethernet; Modbus
Options	Many options for reject and product handling; IP66 option pack; FDA belting; Servo filler/feedback option; Tracker option; Combination system with any Thermo Scientific APEX metal detector; and many more
Certifications	OIML, MID (for OIML, MID and special certifications, some values may vary)

\*Pulleys stainless steel or aluminum. Pharma weigh table in aluminum; for availability consult factory. Box 25 partially aluminum and stainless steel, for availability in what countries, consult factory.

<sup>†</sup>Free-standing conveyor frames are stainless steel, pulleys are stainless steel or aluminum

<sup>‡</sup>Not available in the United States or Latin America

## Thermo Scientific VersaWeigh checkweigher physical dimensions

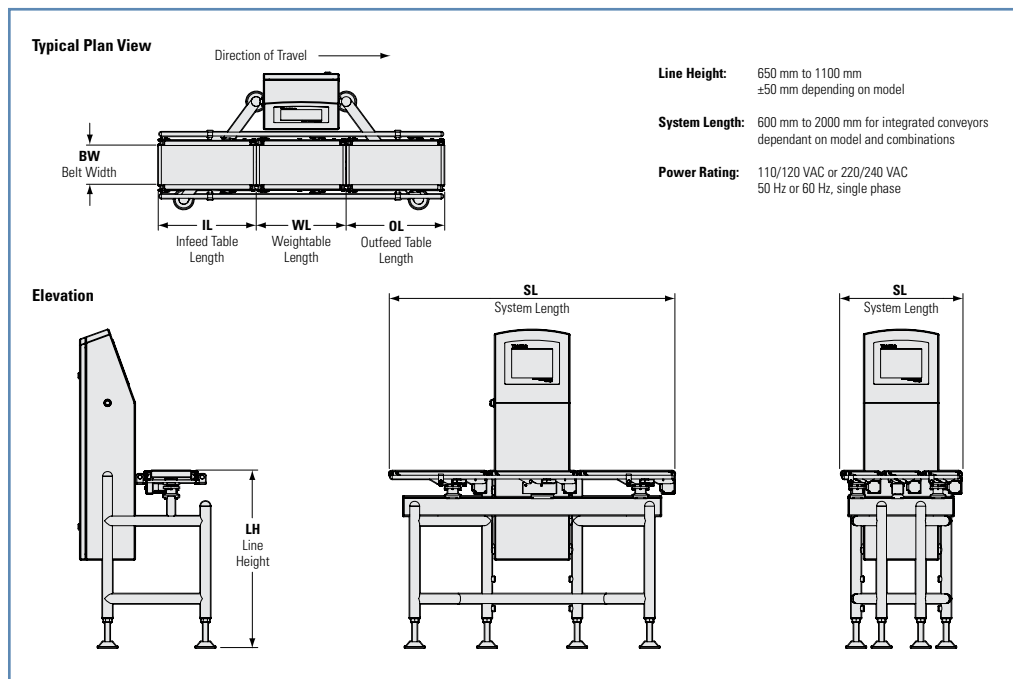

Thermo Scientific™ VersaWeigh checkweighers provide better accuracy at faster speeds to make a real difference on your bottom line and your profitability. Designed to give you outstanding value for the money, these checkweighers can help you identify opportunities where you can improve efficiency and profitability.

### Reduce Training Costs

Designed to eliminate the learning curve, the system operates with a configurable operator access level that uses a standard Microsoft® Windows® XPe and features an easy-to-operate global platform with multi-language capability.

### Minimize Downtime

Easy-to-maintain modular design provides trouble-free operation. Stainless steel frame and durable components mean hours of operation between significant maintenance events. Plus, you don't need tools for belt or most electronic replacements.

### Sustainable

Easy-to-upgrade technology positions the VersaWeigh for future technical enhancements without substantial reinvestment.

For increased functionality, an optional Thermo Scientific APEX metal detector may be seamlessly integrated to provide a complete weight control and contaminant inspection station.

[thermoscientific.com/versa](http://thermoscientific.com/versa)

© 2013 Thermo Fisher Scientific Inc. All rights reserved. All trademarks are the property of Thermo Fisher Scientific Inc. and its subsidiaries. Specifications, terms and pricing are subject to change. Not all products are available in all countries. Please consult your local sales representative for details.

**US and Canada** 800 227 8891  
**Asia/Australia** 800 445 3503  
**Mexico** +52 55 5639 2184  
**Argentina** +54 11 4334 3827  
**Chile** +56 22 2378 5080

**India** +91 22 4157 8800  
**Italy** +39 0 5217 8861  
**France** +33 (0) 16 092 4800  
**Germany** +49 (0) 20 882 4930  
**Spain** +34 (0) 91 484 5965

**UK** +44 (0) 17 8882 0300  
**Netherlands** +31 (0) 76 579 5555  
**South Africa** +27 11 776 0000  
**China** 800 810 5118

Email: [sales.packaging.us@thermofisher.com](mailto:sales.packaging.us@thermofisher.com)

Literature Code PI.0067.0114

**Thermo**  
SCIENTIFIC

Part of Thermo Fisher Scientific